

Hambleside Danelaw Ltd

Long March
Daventry
Northamptonshire NN11 4NR
Tel: 01327 701900 Fax: 01327 701909
e-mail: sales@hambleside-danelaw.co.uk
website: www.hambleside-danelaw.co.uk

Agrément Certificate
87/1915
Product Sheet 1

HAMBLESIDE DANELAW GRP FLASHINGS

HAMBLESIDE DANELAW GRP VALLEY TROUGHS FOR TILED ROOFS

This Agrément Certificate Product Sheet⁽¹⁾ relates to Hambleside Danelaw GRP Valley Troughs for Tiled Roofs, for use in tiled roofs constructed in accordance with the relevant requirements of BS 5534 : 2003 + A1 : 2010. The troughs provide a weatherproof junction where there are changes in direction or material in a roof structure.

(1) Hereinafter referred to as 'Certificate'.

CERTIFICATION INCLUDES:

- factors relating to compliance with Building Regulations where applicable
- factors relating to additional non-regulatory information where applicable
- independently verified technical specification
- assessment criteria and technical investigations
- design considerations
- installation guidance
- regular surveillance of production
- formal three-yearly review.

KEY FACTORS ASSESSED

Weathertightness — as part of a complete roof, the troughs will resist the passage of moisture into the interior of the building (see section 6).

Properties in relation to fire — tests indicate that the troughs, when used as part of a complete roof, will be unrestricted under the Building Regulations (see section 7).

Strength — the troughs have adequate strength to resist the normal loads and impacts associated with the installation of the roof (see section 8).

Durability — under normal service conditions, the troughs will have a service life of at least 20 years (see section 10).

The BBA has awarded this Certificate to the company named above for the products described herein. These products have been assessed by the BBA as being fit for their intended use provided they are installed, used and maintained as set out in this Certificate.

On behalf of the British Board of Agrément

Date of First issue.

Originally certified on 20 September 1987

Simon Wroe

Head of Approvals — Materials

Greg Cooper

Chief Executive

The BBA is a UKAS accredited certification body — Number 113. The schedule of the current scope of accreditation for product certification is available in pdf format via the UKAS link on the BBA website at www.bbacerts.co.uk



THIS IS NOT A VALID AGRÉMENT CERTIFICATE. THE BBA ACCEPTS NO RESPONSIBILITY NOR LIABILITY FOR ANY CONCLUSIONS DRAWN FROM, NOR ANY DECISIONS BASED ON, THIS DOCUMENT.

Regulations

In the opinion of the BBA, Hambleside Danelaw GRP Valley Troughs for Tiled Roofs, if used in accordance with the provisions of this Certificate, will meet or contribute to meeting the relevant requirements of the following Building Regulations (the presence of a UK map indicates that the subject is related to the Building Regulations in the region or regions of the UK depicted):



The Building Regulations 2010 (England and Wales) (as amended)

Requirement:	B4(2)	External fire spread
Comment:		Data to BS 476-3 : 1958 indicate that the products, when used as part of a complete roof, will not affect the fire rating of the roof construction. See section 7 of this Certificate.
Requirement:	C2(b)	Resistance to moisture
Comment:		The products will contribute to a roof meeting this Requirement. See section 6 of this Certificate.
Requirement:	Regulation 7	Materials and workmanship
Comment:		The products are acceptable. See section 10 and the <i>Installation</i> part of this Certificate.



The Building (Scotland) Regulations 2004 (as amended)

Regulation:	8(1)(2)	Fitness and durability of materials and workmanship
Comment:		The use of the products satisfies the requirements of this Regulation. See sections 9 and 10 and the <i>Installation</i> part of this Certificate.
Regulation:	9	Building standards applicable to construction
Standard:	2.8	Spread from neighbouring buildings
Comment:		Data to BS 476-3 : 1958 indicate that the products can be regarded as having a low vulnerability with reference to clause 2.8.1 ⁽¹⁾⁽²⁾ , and will not affect the fire rating of the roof construction. See section 7 of this Certificate.
Standard:	3.10	Precipitation
Comment:		The products will contribute to a roof satisfying clauses 3.10.1 ⁽¹⁾⁽²⁾ and 3.10.8 ⁽¹⁾⁽²⁾ of this Standard. See section 6 of this Certificate.
Standard:	7.1(a)	Statement of sustainability
Comment:		The products can contribute to meeting the relevant requirements of Regulation 9, Standards 1 to 6 and therefore will contribute to a construction meeting a bronze level of sustainability as defined in this Standard.
Regulation:	12	Building standards applicable to conversions
Comment:		Comments made in relation to the products under Regulation 9, Standards 1 to 6, also apply to this Regulation, with reference to clause 0.12.1 ⁽¹⁾⁽²⁾ and Schedule 6 ⁽¹⁾⁽²⁾ . (1) Technical Handbook (Domestic). (2) Technical Handbook (Non-Domestic).



The Building Regulations (Northern Ireland) 2012

Regulation:	23(a)(i)(iii)(b)(i)	Fitness of materials and workmanship
Comment:		The products are acceptable. See section 10 and the <i>Installation</i> part of this Certificate.
Regulation:	28(b)	Resistance to moisture and weather
Comment:		The products will contribute to a roof satisfying this Regulation. See section 6 of this Certificate.
Regulation:	36(b)	External fire spread
Comment:		Data to BS 476-3 : 1958 indicate that the products, when used as part of a complete roof construction, will not affect the fire rating of the roof construction. See section 7 of this Certificate.

Construction (Design and Management) Regulations 2007

Construction (Design and Management) Regulations (Northern Ireland) 2007

Information in this Certificate may assist the client, CDM co-ordinator, designer and contractors to address their obligations under these Regulations.

See sections: 1 *Description* (1.3) and 3 *Delivery and site handling* (3.1) of this Certificate.

Additional Information

NHBC Standards 2013

NHBC accepts the use of Hambleside Danelaw GRP Valley Troughs for Tiled Roofs when installed and used in accordance with this Certificate, in relation to *NHBC Standards, Part 7 Roofs, Chapter 7.2 Pitched roofs*.

1 Description

1.1 Hambleside Danelaw GRP Valley Troughs for Tiled Roofs are manufactured from glassfibre/polyester laminates in a continuous process to the profiles illustrated (see Figures 1 and 2). Mortar bonding strips are provided along the upper surface of each edge as a key for bedding the roof tiles in mortar, where necessary.

Figure 1 Mortared Valley Troughs

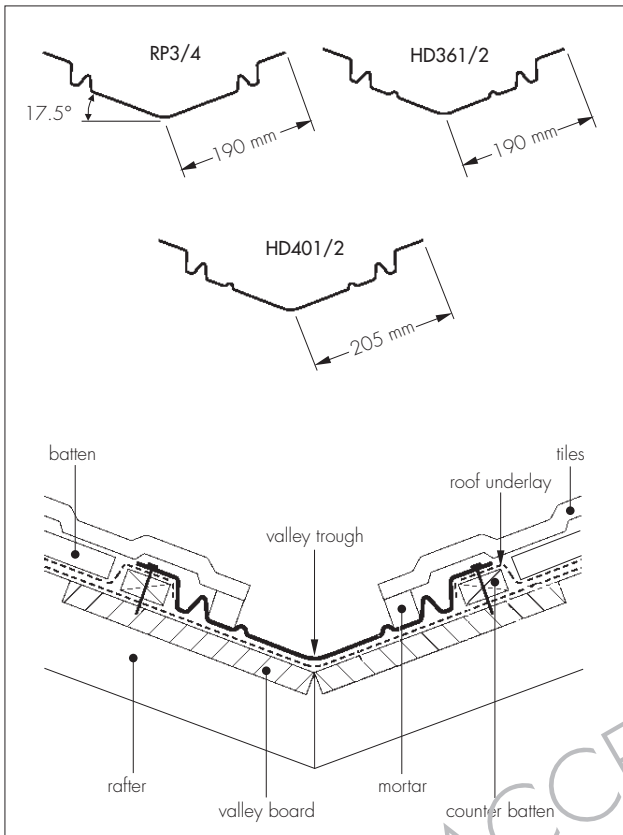
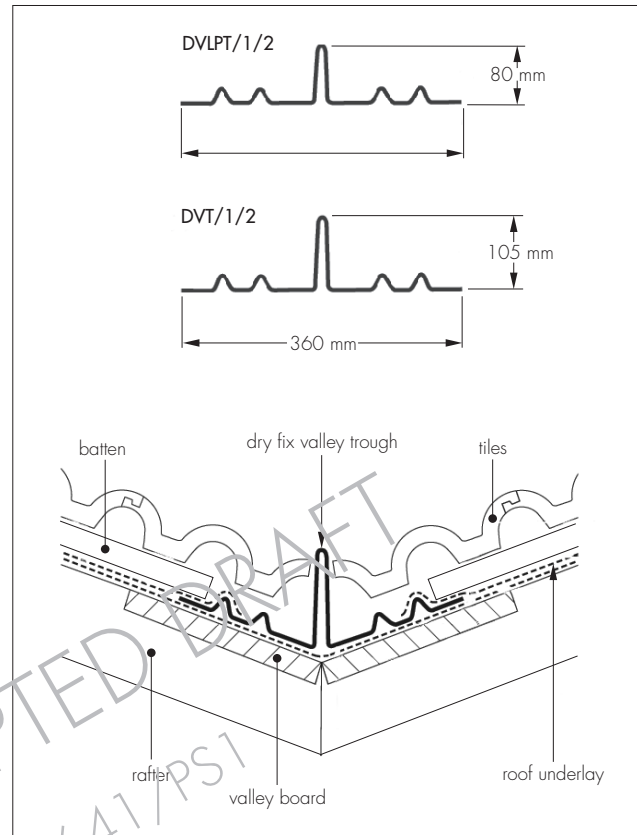

Figure 2 Dry Valley Troughs



1.2 The troughs are available as codes:

- 361 and 362⁽¹⁾ (Tile Valley Troughs)
- 401 and 402⁽¹⁾ (Tile Valley Troughs)
- RP3 and RP4⁽¹⁾ (Tile Valley Troughs)
- DVT/1 and DVT/2 (Dry Fix Valley Troughs)
- DVLPT/1 and DVLPT/2 (Dry Fix Valley Troughs).

(1) Branded as Stormforce 225.

1.3 They are finished in two width sizes (Hambleside Danelaw 400 and 360) and two lengths (2.4 m and 3 m). They are produced with a pitch of 17.5° but can be adapted by bending, to accommodate roof pitches from 17.5° to 60° and a maximum of 20° unequal pitch. The dry fix valley troughs are produced to a flat profile (see Figure 2).

1.4 The products are finished in Standard Grey (other colours are available to order). They are also available with a laminated film on the upper surface which improves the weather resistance of the GRP (glassfibre-reinforced polyester).

2 Manufacture

2.1 Glassfibre mats are impregnated with resin and are laminated with a polyester carrier film and a weather protection film to the required profile.

2.2 As part of the assessment and ongoing surveillance of product quality, the BBA has:

- agreed with the manufacturer the quality control procedures and product testing to be undertaken
- assessed and agreed the quality control operated over batches of incoming materials
- monitored the production process and verified that it is in accordance with the documented process
- evaluated the process for management of nonconformities
- checked that equipment has been properly tested and calibrated
- undertaken to carry out the above measures on a regular basis through a surveillance process, to verify that the specifications and quality control operated by the manufacturer are being maintained.

2.3 The management system of Hambleside Danelaw Ltd has been assessed and registered as meeting the requirements of BS EN ISO 9001 : 2008 by BSI (Certificate FM 23063).

3 Delivery and site handling

3.1 The products are delivered to site in packs of 10 units, each unit marked with size, the application and the BBA identification mark including the number of this Certificate.

3.2 The packs must be stored flat or on end, on a smooth, clean, dry surface, under cover and protected from sunlight.

Assessment and Technical Investigations

The following is a summary of the assessment and technical investigations carried out on Hambleside Danelaw GRP Valley Troughs for Tiled Roofs.

Design Considerations

4 Use

Hambleside Danelaw GRP Valley Troughs for Tiled Roofs are satisfactory for use in tiled pitched roofs constructed in accordance with the relevant clauses of BS 5534 : 2003 + A1 : 2010, to provide a weatherproof junction where there are changes in direction or material in a roof structure.

5 Practicability of installation

Installation is designed to be carried out readily by slaters/tilers experienced with this type or product.

6 Weathertightness



Results of tests indicate that the products will adequately resist the passage of moisture to the interior of a building and so meet the requirements of the national Building Regulations:

England and Wales — Approved Document C, Requirement C2(b), Section 6

Scotland — Mandatory Standard 3.10, clauses 3.10.1⁽¹⁾⁽²⁾ and 3.10.8⁽¹⁾⁽²⁾

(1) Technical Handbook (Domestic)

(2) Technical Handbook (Non-Domestic)

Northern Ireland — Regulation 28(b).

7 Properties in relation to fire



When tested in accordance with BS 467-3 : 1958, samples of GRP representative of that used in the manufacture of the products, achieved an EXT.S:AB rating.

8 Strength

The products will resist the normal loads and impacts associated with installation and use.

9 Maintenance



Minimal maintenance is necessary and the smooth finish will inhibit the build up of foreign matter.

10 Durability



Available test data and knowledge of the material indicate that the products will have an expected life of at least 20 years.

Installation

11 General

Installation of Hambleside Danelaw GRP Valley Troughs for Tiled Roofs must be in accordance with the manufacturer's instructions and the relevant recommendations of BS 5534 : 2003 + A1 : 2010 and BS 8000-6 : 1990 and *NFRC Technical Bulletin 28*.

12 Procedure

Product codes 361, 362, 401, 402, RP3 and RP4 (Tile Valley Troughs)

12.1 The troughs must be fixed onto counter battens, and onto new or existing valley boards. It is recommended that valley boards are used for all valley details, either 6 mm continuous ply boards laid over the rafters or 12 mm ply (or 19 mm softwood) set between the rafters and supported on timber noggings.

12.2 The valley must first be lined longitudinally with BS 8747 : 2007, Type 1F or BBA-approved, roofing underlay for the width of the valley boards. The pitch angle of the valley trough will adapt to suit pitches from 17.5° to 60°.

12.3 Counter battens of the same depth as the tiling battens must be fitted onto the valley boards over the underlay at an appropriate distance from the valley centre to accommodate the trough, and nailed through into the main rafters/trusses below.

12.4 The lengths of trough must be firmly pressed down onto the valley board and then nailed to the counter batten through pre-drilled holes at a maximum of 500 mm centres, using nails of a quality acceptable in good roofing practice.

12.5 The roof tile underlay must then be laid and dressed over the counter batten. Tiling battens must be fitted with the ends firmly located onto the valley boards, positioned close to the counter batten, and taking care not to damage the underlay. The roof tile underlay can then be laid over or under the trough – if laid over the trough, it must not extend beyond the outer water channel.

12.6 The fascia board must be cut to allow the trough to pass through and discharge into the gutter without flattening out. Using a fine-toothed hacksaw, the end of the trough must be trimmed to the approximate centre line of the gutter. Alternatively, a soaker of minimum Code 4 lead may be fitted and dressed into the gutter. The troughs must then be carefully fitted, starting at the foot of the valley, ensuring that they are located centrally on the valley boards, before nailing the sides into the counter battens at 500 mm centres maximum and allowing a 150 mm overlap when measured vertically.

12.7 At the head of the valley, a lead saddle (minimum Code 4) of sufficient length must be fixed to lap over the trough by the same length of lap required between the two valley trough units.

12.8 At dormers, a lead soaker must be used at the base of the valley to dress onto the adjacent tiling. At sprocketed eaves or mansards, separate lengths of trough must be fitted above and below, with a lead saddle of sufficient lap length to link the two parts.

12.9 The tiles must then be laid dry, the cut line marked and the tiles removed before cutting. They can then be re-laid in position, and bedded onto mortar on the bonding strip, ensuring no blockage of the water channels behind the bedding line occurs.

Product codes DVT and DVLPT (Dry Fix Valley Troughs)

12.10 The troughs are designed to fit directly onto new or existing valley boards, in accordance with section 12.1.

12.11 The valley must first be lined longitudinally with BS 8747 : 2007, Type 1F or BBA approved roofing underlay one metre wide, allowing for overlapping into the rainwater gutter. A length of the trough must be both firmly pressed down on to the valley board, as well as pressed together to minimise the gap in the central upstand section. The troughs will hinge to suit a minimum of 17.5° to 60° roof pitch and a maximum of 20° unequal pitch.

12.12 The underlay and battens are fitted in the normal manner, ensuring that the underlay is laid over the outer water bar of the valley. Alternative methods may also be used. Battens must be cut so that they locate onto the flat fixing edges of the valley and nailed through into the supporting boards.

12.13 The fascia board must be cut to allow the trough to pass through and discharge into the gutter. The end of the trough must be trimmed using a fine-toothed hacksaw, to the approximate centre line of the gutter.

12.14 The troughs must be fitted, starting at the foot of the valley. Care must be taken to ensure that they are located centrally on the valley boards, before nailing the sides at a maximum of 500 mm centres to the valley boards using nails of a quality acceptable in good roofing practice.

12.15 Consecutive lengths of the troughs must be laid, allowing a minimum overlap of 150 mm when measured vertically. Where troughs intersect, they must be trimmed with a fine-toothed saw to form a mitred joint and dressed with a lead saddle (minimum Code 4).

12.16 The tiles must be laid in accordance with the manufacturer's instructions. The tiles must be cut to the rake into the valley and abutted against the raised centre section. To avoid distortion, care must be taken not to force the tiles too heavily against it.

12.17 A support bridge (code HD DVBP) to fit over the inner water bar is available to coincide with small cuts of tile that need supporting. Alternatively, a proprietary anti-corrosive tile clip (code HD DVC) may be used.

13 Tests

Tests were conducted and the results assessed to determine:

- density
- glass/resin ratio
- hardness
- cross-breaking strength
- impact resistance
- effect of elevated temperatures
- effect of water soak.

14 Investigations

14.1 An assessment was made of the results of a fire test in accordance with BS 476-3 : 1958 carried out by an independent test authority.

14.2 Visits were made to sites in progress to assess the practicability of installation.

14.3 A survey of users was carried out to assess performance in use.

Bibliography

BS 476-3 : 1958 *Fire tests on building materials and structures — Classification and method of test for external fire exposure to roofs*

BS 5534 : 2003 + Amendment 1 : 2010 *Code of practice for slating and tiling (including shingles)*

BS 8000-6 : 1990 *Workmanship on building sites — Code of practice for slating and tiling of roofs and claddings*

BS 8747 : 2007 *Reinforced bitumen membranes (RBMs) for roofing — Guide to selection and specification*

BS EN ISO 9001 : 2008 *Quality management systems — Requirements*

FINAL ACCEPTED DRAFT
REF: M2/48641/PS1

15 Conditions

15.1 This Certificate:

- relates only to the product/system that is named and described on the front page
- is issued only to the company, firm, organisation or person named on the front page — no other company, firm, organisation or person may hold or claim that this Certificate has been issued to them
- is valid only within the UK
- has to be read, considered and used as a whole document — it may be misleading and will be incomplete to be selective
- is copyright of the BBA
- is subject to English Law.

15.2 Publications, documents, specifications, legislation, regulations, standards and the like referenced in this Certificate are those that were current and/or deemed relevant by the BBA at the date of issue or reissue of this Certificate.

15.3 This Certificate will remain valid for an unlimited period provided that the product/system and its manufacture and/or fabrication, including all related and relevant parts and processes thereof:

- are maintained at or above the levels which have been assessed and found to be satisfactory by the BBA
- continue to be checked as and when deemed appropriate by the BBA under arrangements that it will determine
- are reviewed by the BBA as and when it considers appropriate.

15.4 The BBA has used due skill, care and diligence in preparing this Certificate, but no warranty is provided.

15.5 In issuing this Certificate, the BBA is not responsible and is excluded from any liability to any company, firm, organisation or person, for any matters arising directly or indirectly from:

- the presence or absence of any patent, intellectual property or similar rights subsisting in the product/system or any other product/system
- the right of the Certificate holder to manufacture, supply, install, maintain or market the product/system
- actual installations of the product/system, including their nature, design, methods, performance, workmanship and maintenance
- any works and constructions in which the product/system is installed, including their nature, design, methods, performance, workmanship and maintenance
- any loss or damage, including personal injury, howsoever caused by the product/system, including its manufacture, supply, installation, use, maintenance and removal
- any claims by the manufacturer relating to CE marking.

15.6 Any information relating to the manufacture, supply, installation, use, maintenance and removal of this product/system which is contained or referred to in this Certificate is the minimum required to be met when the product/system is manufactured, supplied, installed, used, maintained and removed. It does not purport in any way to restate the requirements of the Health and Safety at Work etc. Act 1974, or of any other statutory, common law or other duty which may exist at the date of issue or reissue of this Certificate; nor is conformity with such information to be taken as satisfying the requirements of the 1974 Act or of any statutory, common law or other duty of care.